

# **OPTIMEX**

CANNED MOTOR PUMPS

MULTI Range



**DESIGN,  
MANUFACTURING,  
REPAIR**

OPTIMEX is exclusively dedicated to conception, manufacturing, tests and after sales service of Canned Motor Pumps. Created in 1998, our company has been growing ever since, and has become a major actor in this field on the international market.

Used for dangerous, toxic and explosive liquids as well as for major and valuable processes, canned motor pumps are chosen for their robustness and reliability. They confer the highest safety level on the market thanks to its double hermetically sealed containment.

Among others we design and manufacture our pumps according to the following standards:

- ISO 2858, ISO15783, API685, directive 2006/42/EC (Electrical machinery) directive 2014/34/EU (ATEX), EAC (Eurasian Conformity), CUTR (Customs Union Technical Regulations For Belarus, Kazakhstan and Russia), directive 2014/68/EU (Pressure Equipment Directive), RCCM level 3, RCCM-X level 2 and 3.
- OPTIMEX answers the quality management requirements established by ISO 9001 and NF EN 13980.



Remaining attentive to its international customers' requirements, OPTIMEX adapts its production to local Ex-proof directives (ATEX, CUTR, UL, CSA).

**SUMMARY**

- MULTI RANGE DESIGNATION ..... 3
- MULTI RANGE CHARACTERISTICS DIAGRAMS ..... 4
- SPECIFICATIONS OF DESIGN ..... 6
- MATERIALS ..... 8
- SLIDE BEARINGS ..... 9
- ARRANGEMENT DRAWING ..... 10
- CIRCULATION PLANS ..... 12
- THRUST BALANCING SYSTEM ..... 13
- DESIGN AND MANUFACTURING FEATURES ..... 14
- CONTACTS ..... 16

**+ MULTI RANGE DESIGNATION**

Needs of high Total Discharge Head (TDH) require the use of Multi-stage pumps. OPTIMEX focused on developing a range of products that would fit all requirements from the Chemical, the Energy and the Oil & Gas industries' requirements. Even if the API685 does not cover this kind of pumps, OPTIMEX respects, on demand, all its applicable paragraphs.

Now recognized for its imposing achievements for critical applications (such as liquefied gas), OPTIMEX is strongly appreciated for its skills and know-how.

Each OPTIMEX pump is identified by a unique serial number (BFXXXX) and a complete designation name that reflects all its main characteristics (regarding hydraulic and motor selection, design specificities and main construction options).

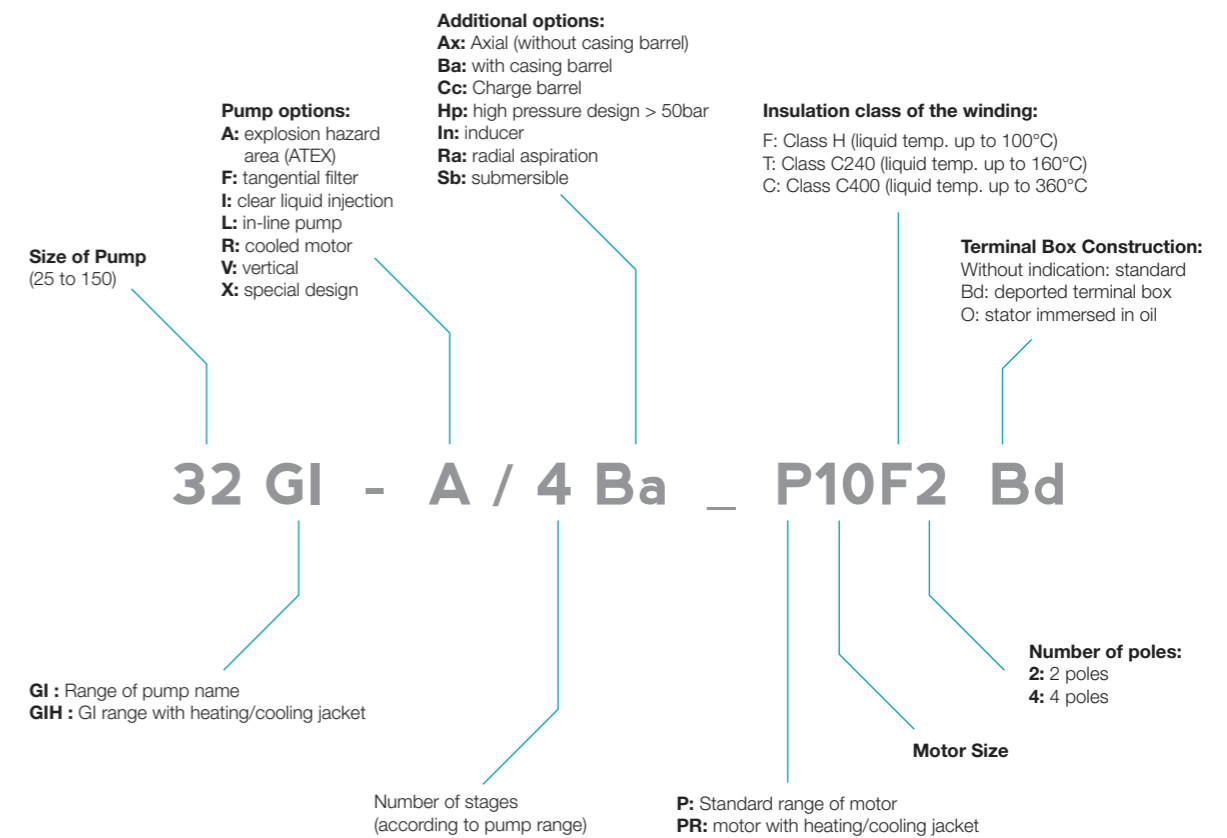

After a standard set of tests and inspections, our pumps are delivered with a standard documentation's list.

**STANDARD DOCUMENTATION:**

- Vendor's data sheet + curve
- Instrumentation list + manuals
- General arrangement drawings
- Cross Sectional drawing with parts list
- Spare part list advised by OPTIMEX
- Operation and maintenance instruction
- Vendor Data Book
- Ex-Proof certificate (ATEX, CUTR or other upon request and confirmation by OPTIMEX)
- CE declaration of conformity

**STANDARD CONTROLS:**

- Balancing test following ISO 1940
- Hydrostatic tests
- Performance test (QHP) following ISO 9906 with API 685 tolerances (5 points)
- Balancing system test: axial thrust measurement
- Final sealless test with air
- Motor insulation test

Other document/test/inspection or certificate can be proposed upon request and after OPTIMEX confirmation.

## + MULTI RANGE CHARACTERISTICS DIAGRAMS

The performance curve gives a complete picture of the available head and flow, for a given pump designation, according to the impeller's diameter and size, and the number of stages.  
Our pumps are available for two types of power supplies: 50Hz and 60Hz.  
The motor can also be driven by a frequency converter, in order to have variable speed control.

PERFORMANCE CURVE - 50HZ / 1450 RPM

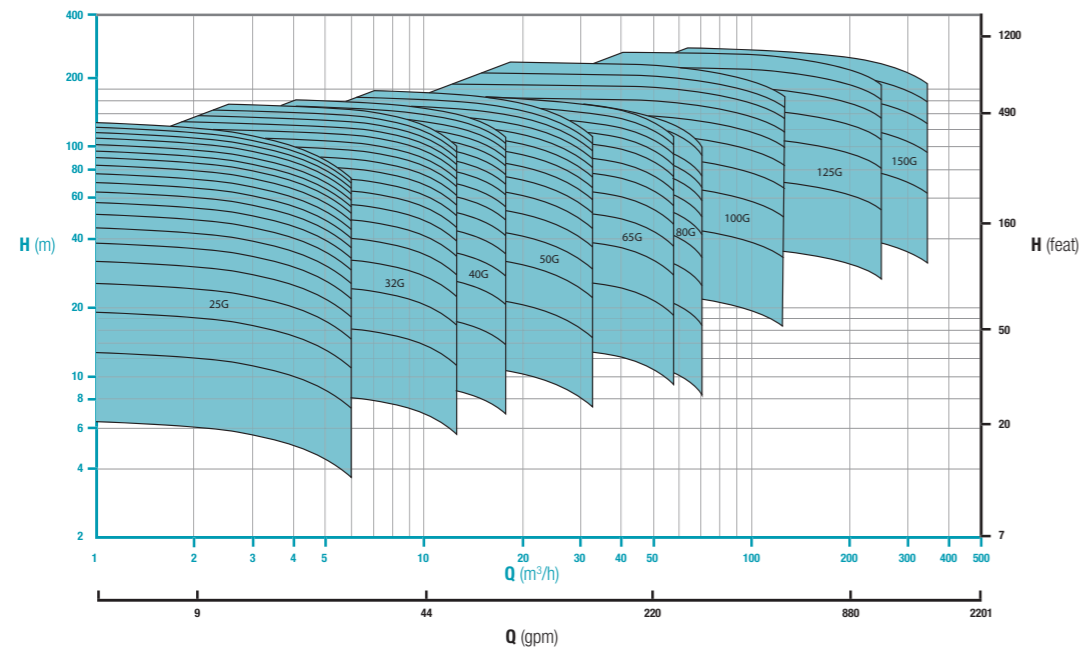

PERFORMANCE CURVE - 50HZ / 2900 RPM

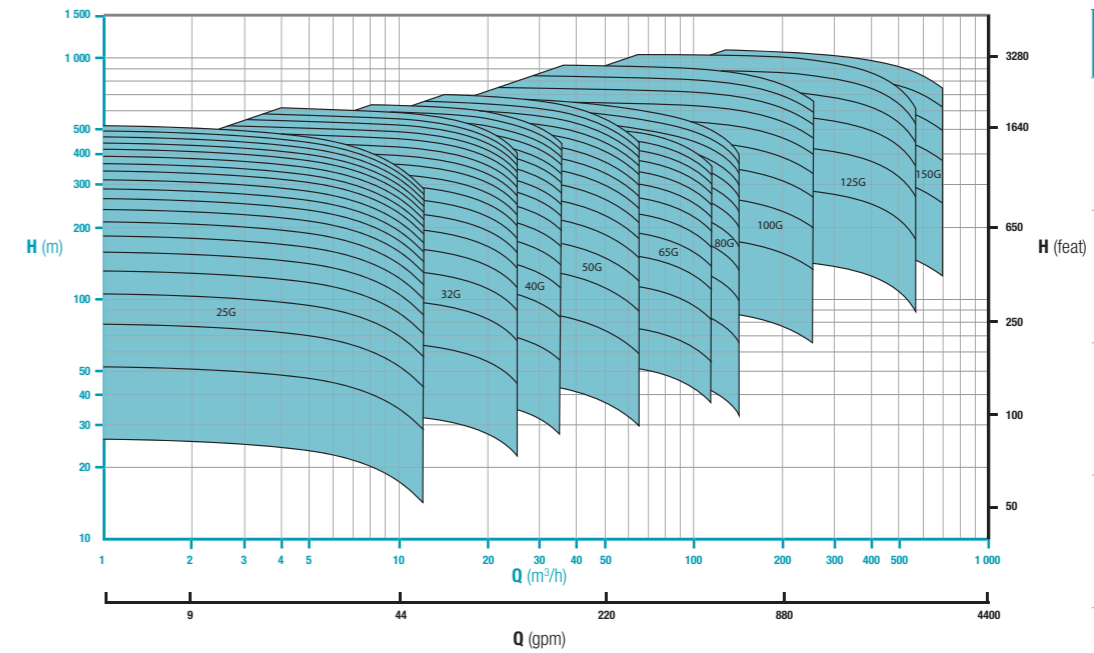

PERFORMANCE CURVE - 60HZ / 1750 RPM

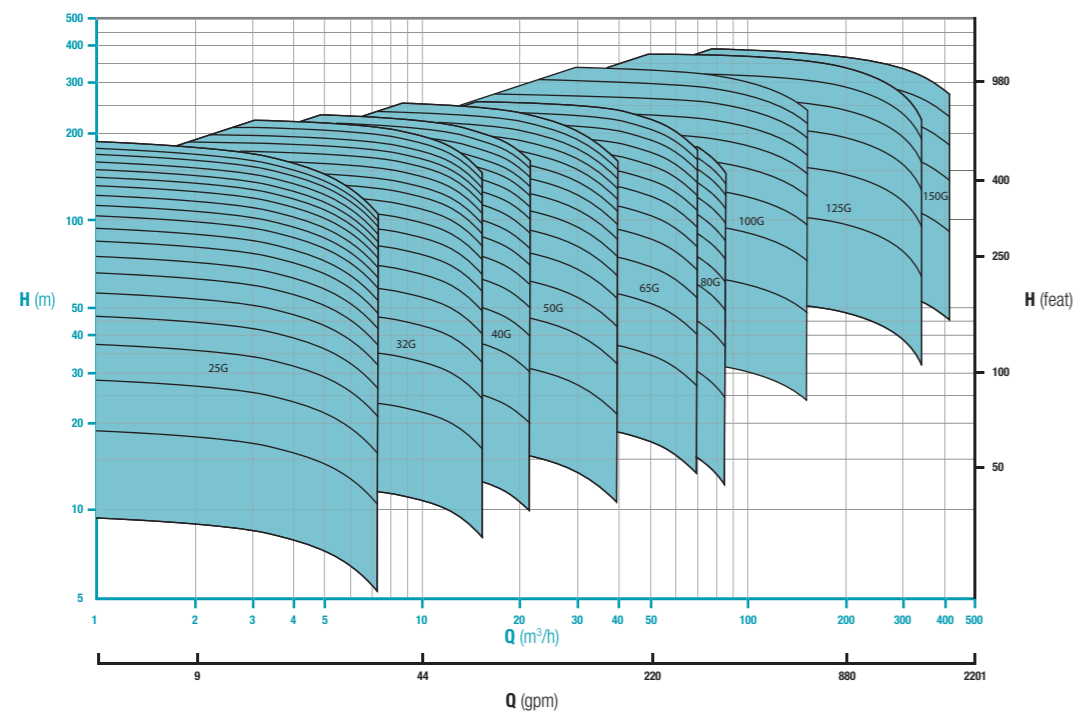

PERFORMANCE CURVE - 60HZ / 3500 RPM

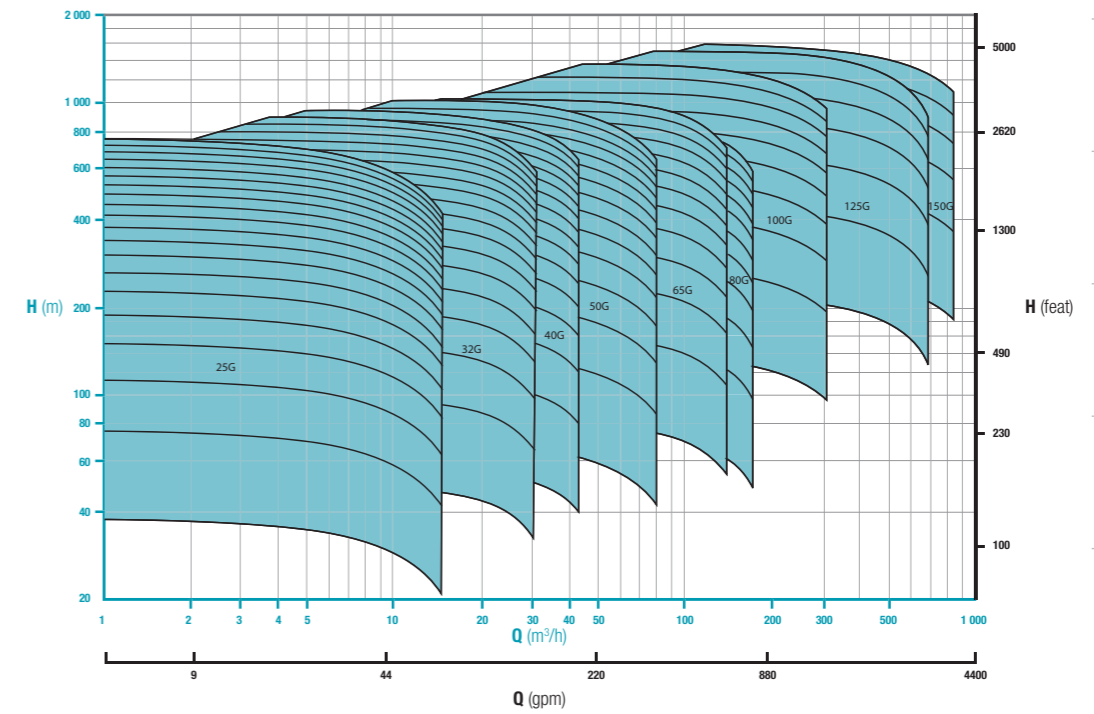

Number of stages per range of pump:

25G: 2 to 20 Stages

32G: 2 to 18 Stages

40G: 2 to 16 Stages

50G: 2 to 15 Stages

65G: 2 to 13 Stages

80G: 2 to 12 Stages

100G: 2 to 10 Stages

125G: 2 to 7 Stages

150G: 2 to 6 Stages

**+ SPECIFICATIONS OF DESIGN**

**STANDARD CONSTRUCTION**

- 1 Standard flanges according to ASME B16.5, Class 300 RF
- 2 Thrust balancing system (p.13)
- 3 Loose flange: allows adaptability between different motors and hydraulics of the Multi Range
- 4 Motor frame with same design pressure as the pump
- 5 Leak proof feedthrough with same design pressure as the pump
- 6 Terminal box: in "e" protection
- 7 Drainable second containment

**CONSTRUCTION OPTIONS**

- Welded drain with flange and valve
- SIC30 slide bearings: detailed page 9
- Inducer: for low NPSH application
- Circulation plan selection: detailed page 12
- With or without casing barrel
- Vertical or horizontal mounting
- Hydraulic and motor heating or cooling jacket
- Stator immersed in oil (detailed page 15)
- Additional separate instrumentation junction box

**INSRUMENTATION OPTIONS**

- A Control of the liquid temperature at the hottest point of the pump.
- B Winding overheat protection PT100 or/and PTC
- C Control and monitoring of the second containment pressure: to detect the stator liner failure
- D Control and Monitoring of the mobile position, mounted on the rear bearing support: to detect any deviance of thrust balancing or bearings capacity.
- E Rotating direction indicator with local sensor: to guarantee the appropriate electrical connection

Other instrumentations can be supplied for your installation, such as liquid level switch, power controller, frequency converter...

**IMPORTANT:** Minimum requirement in hazardous area is liquid level control and temperature control

- Moving parts
- Fixed parts
- hermetically sealed casing

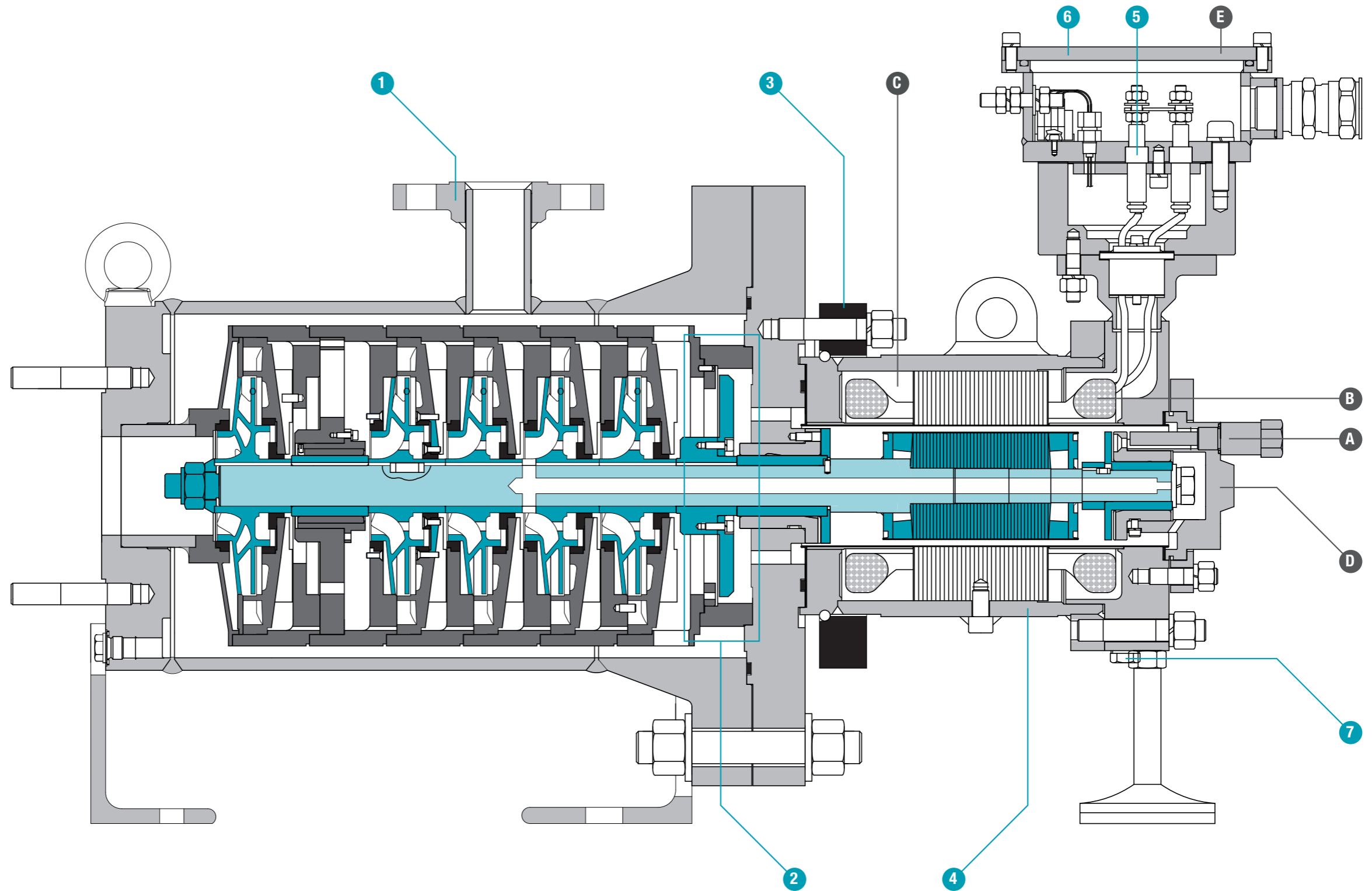

**+ MATERIALS**

In accordance with the materials required by API685, OPTIMEX has made a standard selection that covers to its maximum your usual applications, in terms of liquid compatibility and operating temperature range.

**MULTI-STAGE PUMP WITHOUT CASING BARREL**

	Pressure Casing			Impeller	Wear Ring	Motor casing	Shaft
	Castings	Forgings	Tubes				
S1 T>-20°C	A216WCB	A350LF2	A106 Gr B	A48 Class 35	A410 +T	A519 Gr1524 A519 Gr1518	A519 Gr4140 + A276 Type 420
S5 T>-20°C				A216WCB			
S6 T>-20°C				A487 Ca6MN			
S8 T>-20°C				A351 Gr CF3M			
A8	A351 Gr CF3M	A479 Type 316L	A312 Type 316L	A351 Gr CF3M	A312 Type 316L + T		A276 type 316L

**MULTI-STAGE PUMP WITH CASING BARREL**

	Pressure Casing		Castings	Impeller	Wear Ring	Motor casing	Shaft
	Forgings	Tubes					
S1# T>-20°C	A350LF2	A106 Gr B	A536 Gr65-45-12	A48 Class 35	A410 +T	A519 Gr1524 A519 Gr1518	A519 Gr4140 + A276 Type 420
S1# -20>T>-46°C	A350LF2 CI1	A333Gr6					
S5# T>-20°C	A350LF2	A106 Gr B	A216WCB	A216WCB			
S5# -20>T>-46°C	A350LF2 CI1	A333Gr6	A487 Ca6MN	A487 Ca6MN			
S6# T>-20°C	A350LF2	A106 Gr B	A351 Gr CF3M	A351 Gr CF3M	A312 Type 316L + T		A479 Type 316L
S6# -20>T>-46°C	A350LF2 CI1	A333Gr6					
S8# T>-20°C	A350LF2	A106 Gr B					
S8# -20>T>-46°C	A350LF2 CI1	A333Gr6					
A8	A479 Type 316L	A312 Type 316L					

**STANDARD FLANGES RATING IS #300 IN ACCORDANCE WITH ASME B16.5.**

Maximum acceptable pressure versus the operating temperature are described in the graphic below.

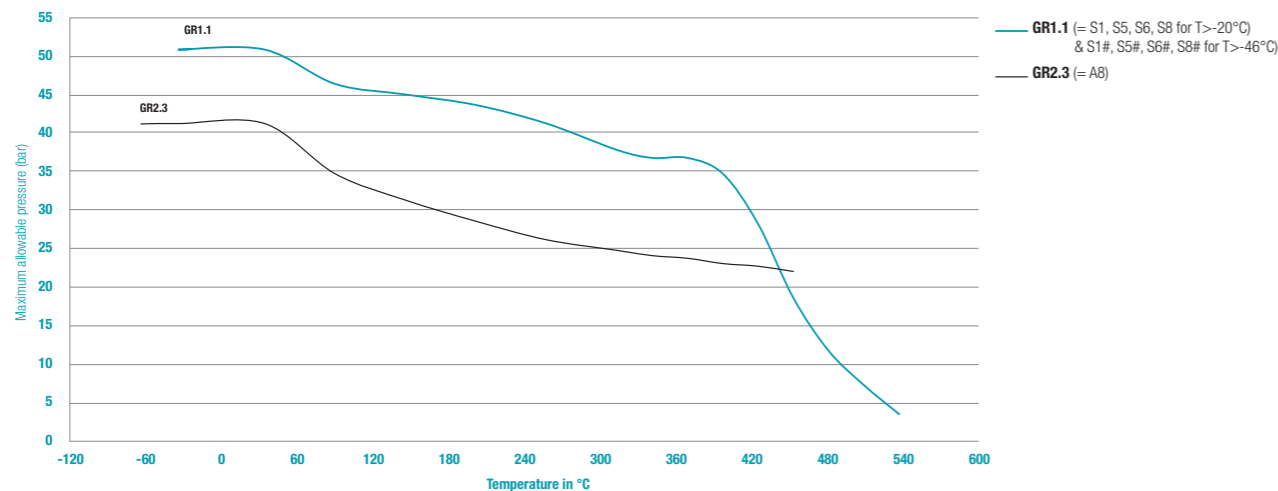

**+ SLIDE BEARINGS**

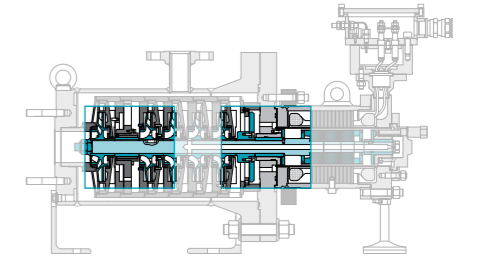

Slide bearings are one of the major parts that confer such a good reliability to seal-less pumps.

In multi stages canned motor pumps, the monobloc shaft composed of all the rotating elements of the machine is supported by two types of slide bearings that are totally submersed in the pumped liquid:

**A:** The motor bearings: they are by 2 on every machine.

**B:** The intermediate bearings: their quantity is defined depending on the number of stages of the pump.

Once the pump's filling is guaranteed (and controlled with the appropriate instrumentation), the pump can be started.

The mobile will rotate free from any friction and wearing, thanks to a thin film created by the pumped liquid ensuring the radial thrust.

**316L/GRAPHITE**

For standard applications, graphite bearings are proposed. Parts and composition are shown below.

**316Ti/TUNGSTEN CARBIDE COATING/SIC30**

For critical applications with risks of dry running (frequent and delicate start-up or critical liquids for which full characteristics have been transmitted and approved by OPTIMEX), SIC30 bearings are advised and proposed.

Parts and composition are shown below.

In case of bearing capacity losses, friction between sleeve in SIC30 and specific coating on shaft sleeve is acceptable for small periods.

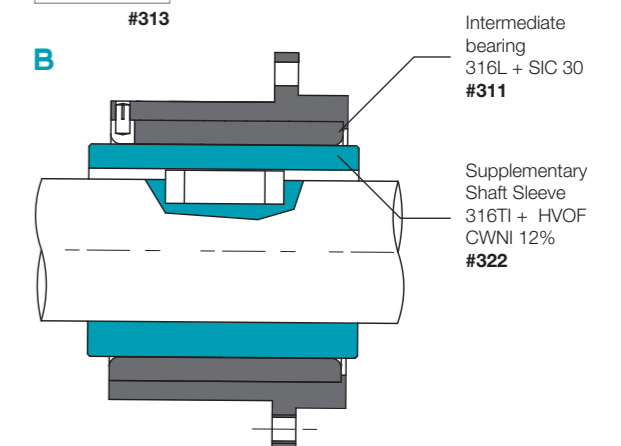
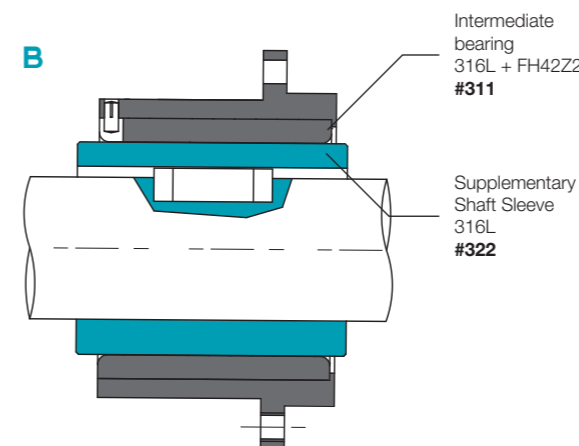
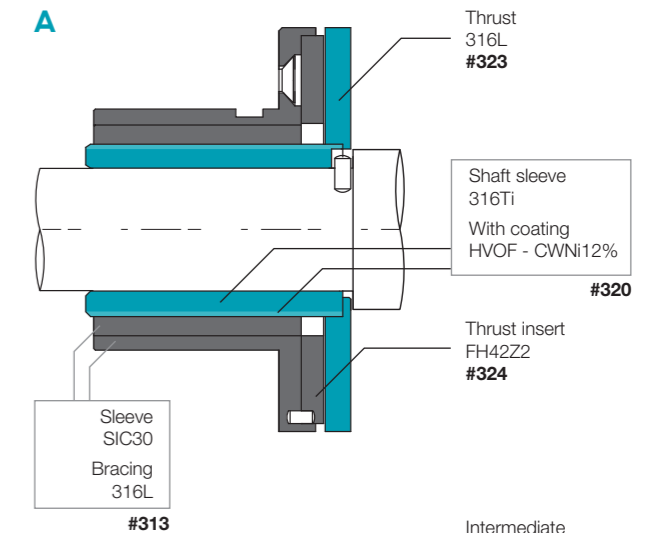
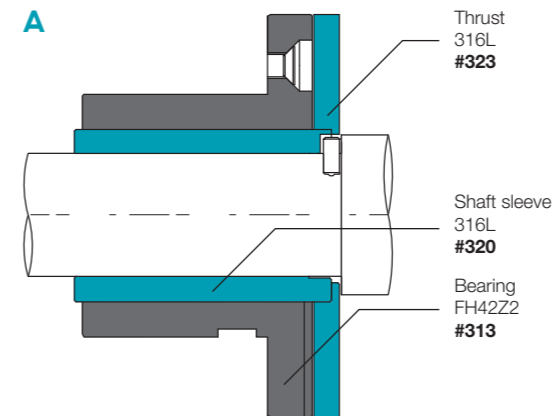

■ Fixed parts  
■ Moving parts

**+ ARRANGEMENT DRAWING**

Here is an arrangement drawing of a standard multi-stage pump in casing barrel.  
On demand, we can provide more arrangement drawings that would include your construction's options.

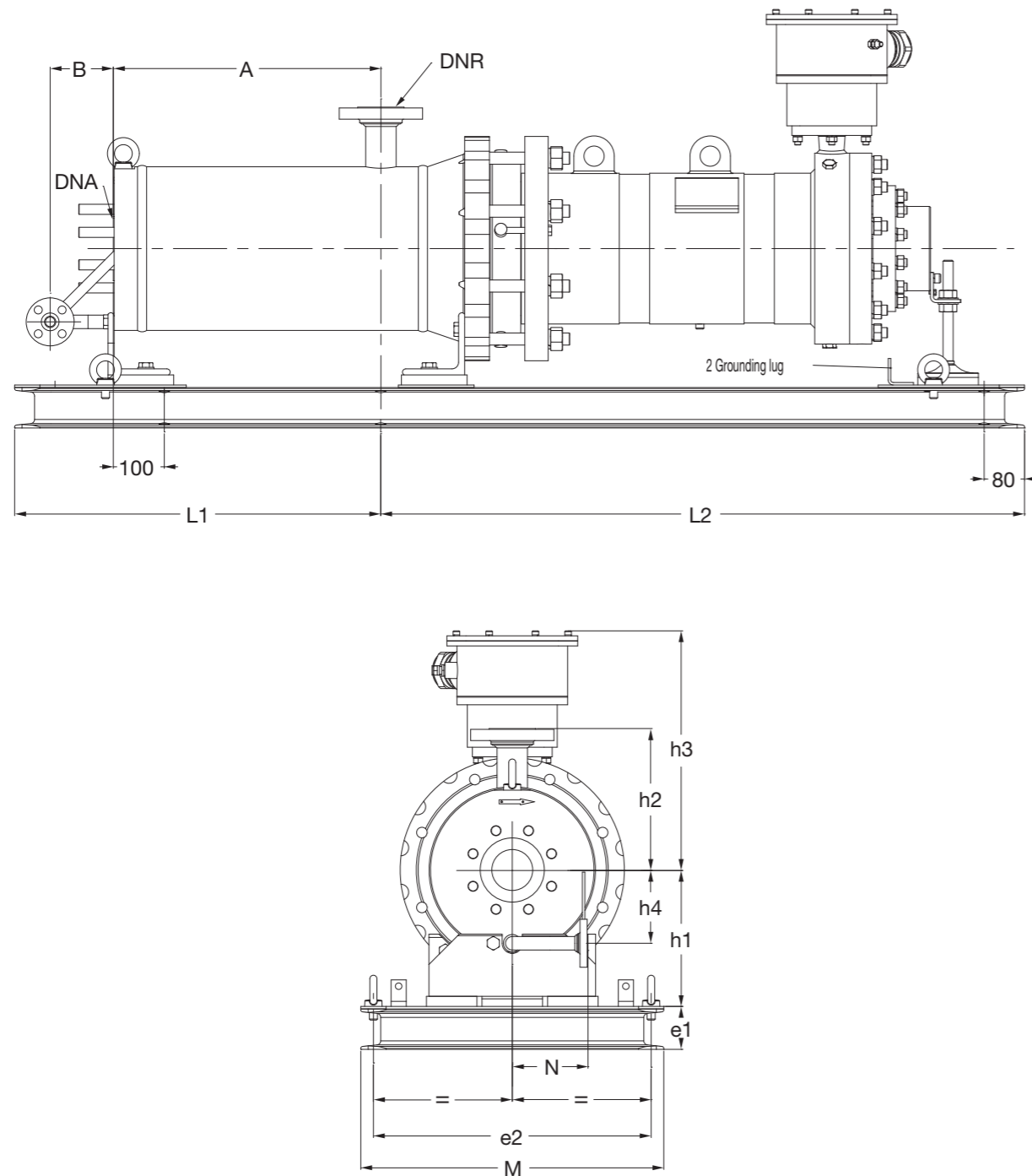

The following tables indicate the various dimensions of our pumps according to their hydraulic, motor type and number of impellers.

If we take the example of the pump designated page 3:

**32 GI - A / 4 Ba \_ P10F2**

Size of pump	32G
Motor Type	P10
Number of impellers	4

All dimensions are defined according to these information and highlighted in the following tables for this specific example.

Pumps' stable dimensions according to the hydraulic selection:

SIZE OF PUMP	DNA inches	DNR inches	h1 mm	h2 mm	M mm	e2 mm	B mm	h4 mm	N mm
25G	2"	1"	200	225	500	450	100	98,5	140
32G	3"	1" 1/2	250	225	600	550	125	120	150
40G	3"	1" 1/2	250	225	600	550	125	120	150
50G	3"	2"	250	280	600	550	125	145	150
65G	4"	3"	250	315	600	550	125	145	200
80G	6"	4"	355	355	700	650	150	183	200
100G	6"	4"	355	355	700	650	150	183	200

Pumps' variable dimensions according to hydraulic's size and number of stages on the pump:

SIZE OF PUMP	Motor type										
	P4	P7	P10	P15	P30	P37	P45	P69	P80	M100	M120
25G	800	1000	1000	1000	1000	1200					
32G	800	1000	1000	1000	1000	1200	1400	1600			
40G	800	1000	1000	1000	1000	1200	1400	1600	1600	1600	1600
50G	800	1000	1000	1000	1000	1200	1400	1600	1600	1600	1600
65G				1000	1200	1200	1400	1600	1600	1600	1600
80G					1200	1200	1400	1600	1600	1800	1800
100G							1400	1600	1600	1800	1800
Baseplate : e1 mm	85	85	85	85	85	85	105	105	105	105	105
Junction box: h3 mm	335	335	335	415	415	415	460	460	460	572	572

Pumps' variable dimensions according to the sizes of the pumps' hydraulic and stages' number:

SIZE OF PUMP	Number of impellers																		
	2	3	4	5	6	7	8	9	10	11	12	13	14	15	16	17	18	19	20
A mm	120	120	177	291	348	405	462	519	633	690	747	804	861	975	1032	1089	1146	1203	1317
L1 mm	400	400	400	600	600	600	800	800	800	1000	1000	1000	1200	1200	1200	1400	1400	1400	1600
A mm	133	133	190	304	361	418	475	532	646	703	760	817	874	988	1045	1102	1159		
L1 mm	400	400	400	600	600	600	800	800	1000	1000	1000	1200	1200	1400	1400	1400			
A mm	158	158	158	282	344	406	468	530	654	716	778	840	902	1026	1088				
L1 mm	400	400	400	600	600	600	800	800	1000	1000	1000	1200	1200	1400	1400				
A mm	140	140	205	335	400	465	530	595	725	790	855	920	985	1115					
L1 mm	400	400	400	600	600	800	800	800	1000	1000	1200	1200	1400						
A mm	235	235	235	315	395	475	555	635	715	795	875	955							
L1 mm	600	600	600	600	600	800	800	800	1000	1000	1200	1200							
A mm	220	220	315	410	505	600	695	790	885	980	1075								
L1 mm	600	600	600	800	800	1000	1000	1000	1200	1200	1400								
A mm	220	220	315	410	505	600	695	790	885										
L1 mm	600	600	600	800	800	1000	1000	1000	1200										

## + CIRCULATION PLANS

According to the operating conditions and fluid properties, OPTIMEX selects the appropriate circulation plan to optimize the functioning of the pump. See above our standard circulations for normal conditions, liquefied gas (pressurized), hot liquids (cooling loop) and liquids with particles (filtered). For critical applications, OPTIMEX can develop customized circulation plan to guarantee a good lubrication and cooling of the motor.

### N: NORMAL CIRCULATION

OPTIMEX ref.	Liquid in the motor	Circulation description	Diagram
N2	Pumped liquid	Injection in the motor from the hydraulic casing (at the impeller periphery), circulation through the gap, and return to the pump casing, between two impellers, via the hollow shaft.	

### R: COOLED CIRCULATIONS

OPTIMEX ref.	Liquid in the motor	Circulation description	Diagram
R2	Pumped liquid	Pumped liquid and motor liquid are identical and they slightly communicate in order to establish an equipressure between the 2 areas (high and low temperature). On the motor side the liquid circulates in an external heat exchanger, flow is established by an auxiliary impeller. A thermal barrier is built between the hydraulic casing and the motor (air or water).	
R6	Pumped liquid	Injection in the motor from the hydraulic casing (at the impeller periphery), circulation through the gap, and return to the pump casing, between two impellers, via the hollow shaft. The process flow is discharged through a double casing around the motor, in order to evacuate the calories externally, and to complete the cooling of the internal circulation.	

### F : FILTERED CIRCULATIONS

OPTIMEX ref.	Liquid in the motor	Circulation description	Diagram
F2	Filtered pumped liquid	Injection in the motor through an external pipe from a self-cleaning tangential filter, circulation through the gap, and return to the pump casing, in between two impellers, via the hollow shaft.	

### SR : COOLED OVERPRESSURED CIRCULATIONS

OPTIMEX ref.	Liquid in the motor	Circulation description	Diagram
SR6	Pumped liquid	A part of the liquid called « process flow » is discharged through a double casing around the motor, in order to evacuate the calories externally, and to complete the cooling of the internal circulation. A second part of the liquid is injected in the motor from the hydraulic casing (via a auxiliary impeller), then circulates through the gap, and is re-injected to the process flow at the rear bearing support.	

## + THRUST BALANCING SYSTEM

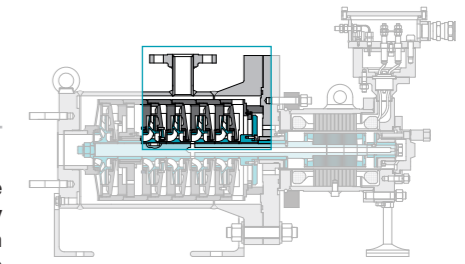

Over the years OPTIMEX has developed a performing and reliable thrust balancing system for its MULTI Range. It is one of the key factors that leads OPTIMEX to become a reference for designing such equipment. Indeed, the compensation of the radial forces implied by the large number of centrifugal impellers is essential to operate the MULTI pumps in good conditions with high reliability. OPTIMEX know how and experience gave the opportunity to design and manufacture some of the largest and imposing realizations on the market.

Each of the impellers, is partially self-balanced with a stable restriction orifice located at its rear **1**.

Still, it is not fully efficient and sufficient, and residual negative force pull the mobile to the suction side. Moreover the system must be dynamic to regulate the complete mobile's position in function of the whole operating range.

To achieve a complete balancing, a piston **2** is used to create a variable gap **3** which regulates the pressure in the regulating chamber **4**.

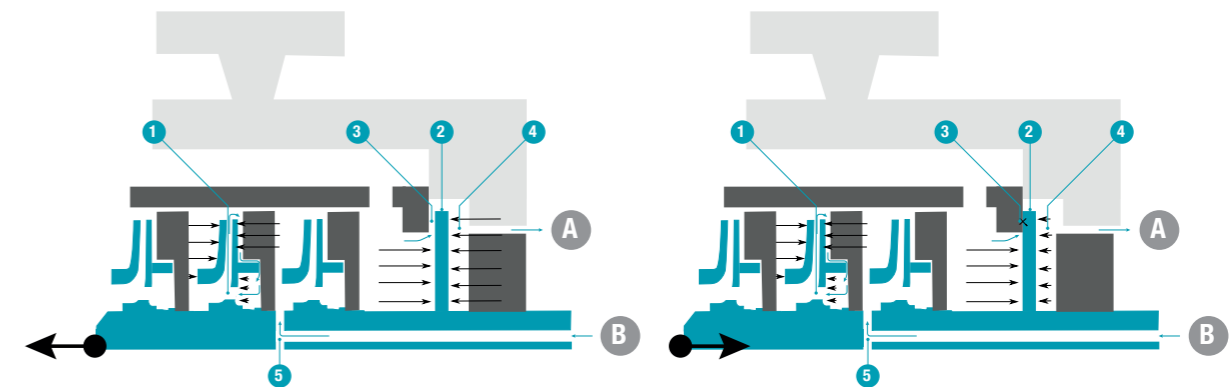

**If the mobile moves to the rear:**

Gap is wide, and losses are low. As a consequence, regulating chamber's pressure is high. Resultant of the force is negative, the mobile moves back to the front.

**If the mobile moves to the front:**

Gap is nearly closed. Regulating chamber's pressure decreases down to lower pressure from an intermediary impeller through the hollow shaft **5**. Resultant is positive, the mobile moves back to the rear.

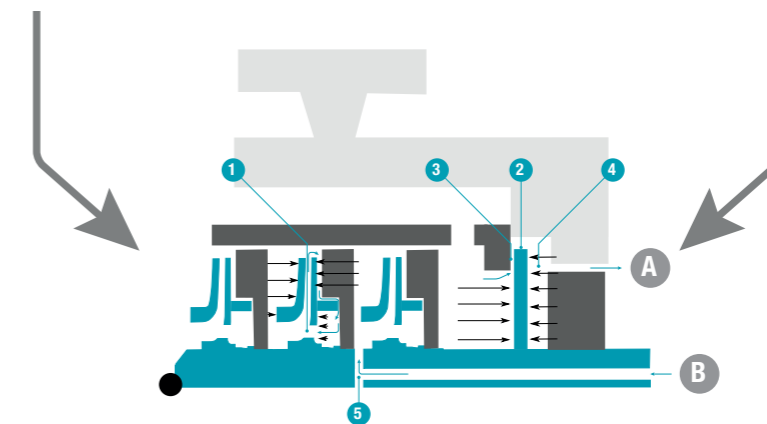

In the stable functioning phase, pressure in the chamber is regulated between high and low pressure. Resultant force is null and the mobile remain perfectly balanced without any friction.

Axial thrust balancing of every MUTLI pump is checked on the full operating range during performance test.

- A** To the rotoric chamber for lubrication and cooling
- B** From the rotoric chamber for pressure balancing to the suction of an intermediary impeller

- Circulation
- Pressure
- Displacement

- Fixed parts
- Moving parts

## + DESIGN AND MANUFACTURING FEATURES

In accordance with our customers' various applications and requirements, Optimex is able to manufacture several types of Multi-stage Canned Motor Pumps.

### HORIZONTAL DESIGNS

**N2**  
Horizontal Multi-stage Pumps **without** casing barrel.

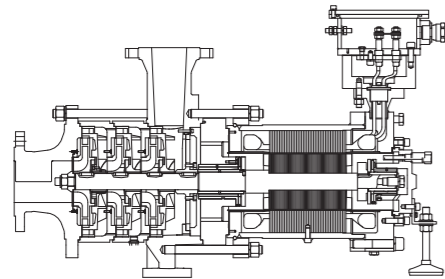

**N2-Ba**  
Horizontal Multi-stage Pumps **with** casing barrel:  
• Less static sealings

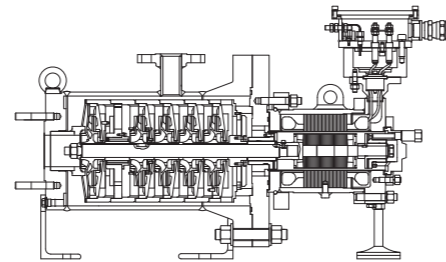

+ ✓ Without design pressure limits

### VERTICAL DESIGNS

**N2-V**  
Vertical Multi-stage Pumps in casing barrel with chair baseplate:  
• reduced radial load on slide bearings

+ ✓ Low viscosity application  
✓ Space saving on the floor  
✓ Customized arrangement

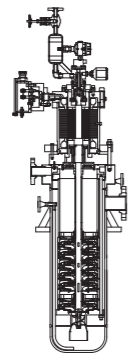
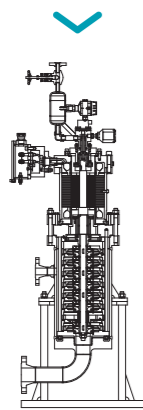

**N2-VCc**  
Vertical Multi-stage Pumps with external motor, with or without charge barrel.

+ ✓ NPSH available increase  
✓ Possibility to fit on existing tank (via a manhole) or barrel

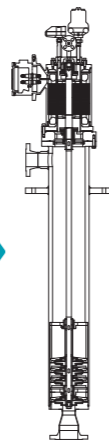

**N2-LV**  
Vertical Multi-stage Pumps with casing barrel:  
• Inline flanges  
• Possibilities to fit in place

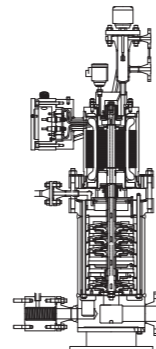

### SUBMERGED DESIGNS

**N2-VCcSub**  
Vertical Multi-stage Pumps with submerged hydraulic and motor.

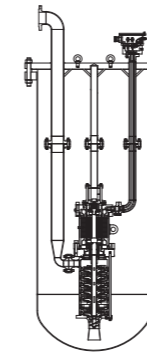

+ ✓ Totally submerged solution  
✓ Without long shaft line  
✓ Low NPHa application

**N2-Vsub**  
Vertical Multi-stage Pumps with totally submerged canned motor and dry stator.

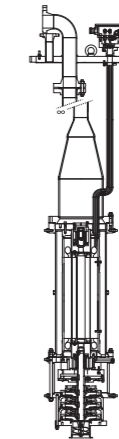

+ ✓ Possibility to fit on existing tank (via a manhole) or barrel  
✓ Space saving  
✓ Axial discharge line

### LIQUIFIED GAS / SEVERE APPLICATIONS DESIGN

**R6-VCc & SR6-VCc**  
Vertical Multi-stage Pumps with submerged canned motor.

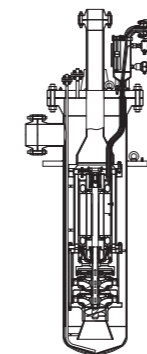

#### Customers requirements:

- Low NPSH available
- High risk of vaporization (vapor pressure up to 35 bar)
- Liquid with presence of conductive elements (mercury, sea water...)
- High static pressure
- Needs for high reliability
- Security priority

#### + OPTIMEX Solutions:

- ✓ Oil immersed canned stator:  
- for better heat dissipation around the winding  
- no contact between winding and conductive elements
- ✓ 100% of the process flow is used to cool down the motor (rotoric circulation + double shell around the stator)
- ✓ Possibility of over pressurized motor to avoid risk of vaporization
- ✓ Maximal limitation of wear part: hydrodynamic and magnetic balancing
- ✓ Submerged motor without long shaft





269, rue de Montepy  
69210 Fleurieux sur l'Arbresle  
France

Tél : +33 (0)4 72 52 95 74  
contact@optimex-pumps.com

[www.optimex-pumps.com](http://www.optimex-pumps.com)