

OPTIMAG  
MAGNETIC DRIVE  
PUMP  
CNM range



DESIGN,  
MANUFACTURING,  
REPAIR

**DESIGN,  
MANUFACTURING,  
REPAIR**

OPTIMEX is a French company dedicated to design, manufacturing, tests and after sales services of sealless pumps. Since 1998, our company has been growing and became a major actor in this field on the international market.

Our magnetic drive pumps range OPTIMAG has been developed to be used on severe applications and brings a very high safety level thanks to its sealless design. Sized as per ISO2858 chemical standards, OPTIMAG range can fit in place of any other normalized pumps, even mechanical sealed pumps.



**+ CNM RANGE  
SAFETY, SIMPLICITY, RELIABILITY AND COST EFFICIENCY**

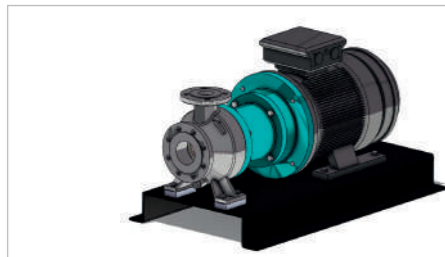

**WORKING RANGE:**

Flow ..... Up to 300 m<sup>3</sup>/h  
Head ..... Up to 140 m  
Frequency ..... 50Hz/60Hz  
Pumping temperature ..... -120°C / 140°C  
Pressure design ..... Up to 16 bar

**+ CONSTRUCTION:**

The CNM range construction is based on a standard centrifugal hydraulic coupled with a standard motor through a magnetic coupling. This design eliminates the mechanical seal and increase significantly the level of safety toward risk of leakage of an hazardous pumped liquid.

**BEARINGS:**

- Our CNM range is equipped with a slide bearing which is one of the major part that confers such a good reliability to sealless pumps.
- The bearing is located on the monobloc shaft composed of all the rotating elements submersed in the pumped liquid. Once the pump's filling is guaranteed (and controlled with appropriate instrumentation) and pump is started, the mobile rotates free from any friction and wearing thanks to a thin film of liquid.

**CONSTRUCTION OPTION**

- 2 options are available:
- Monobloc construction: a very compact pump, with an easy installation thanks to unnecessary lineage. Compliance to ISO2858 hydraulic casing dimensions to allow standardized mechanical seal pumps replacment without any piping adaptation.
  - Frame construction: full compliance to the ISO2858 and ISO3661. The pump and its baseplate can fit in place of any standardized mechanical seal pumps without any civil work or user's interfaces adaptation.

**+ DOCUMENTATION:**

- Documentation delivered with the pump is compliant with CE requirements.
- User manual
  - Sectional drawing with parts list
  - Hydraulic curve
  - Dimensional drawing
  - Conformity certificate
  - Test report

**CERTIFICATES:**

- **Material certificates**  
On demand we can deliver certificate 2.2 or 3.1 according to EN 10204.
- **Hydrostatic certificate**  
Each pump is tested at 1.5 times the design pressure
- **Performance test certificate**  
Each pump is tested according to ISO 9906 grade 2. On demand, we can deliver a NPSH test.

**+ PUMP DESIGNATION:**

Each OPTIMEX pump is identified by a unique serial number (BFEMxxx) and a complete designation code which reflects all main characteristics of the pump.

**CNM-A 32/160 In\_MB\_IEC100-2**

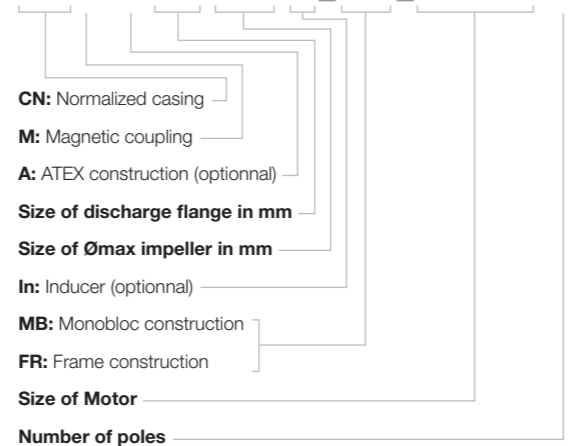

**+ CNM PERFORMANCE CURVES**

**CURVE RANGE 50HZ / 2900 RPM**

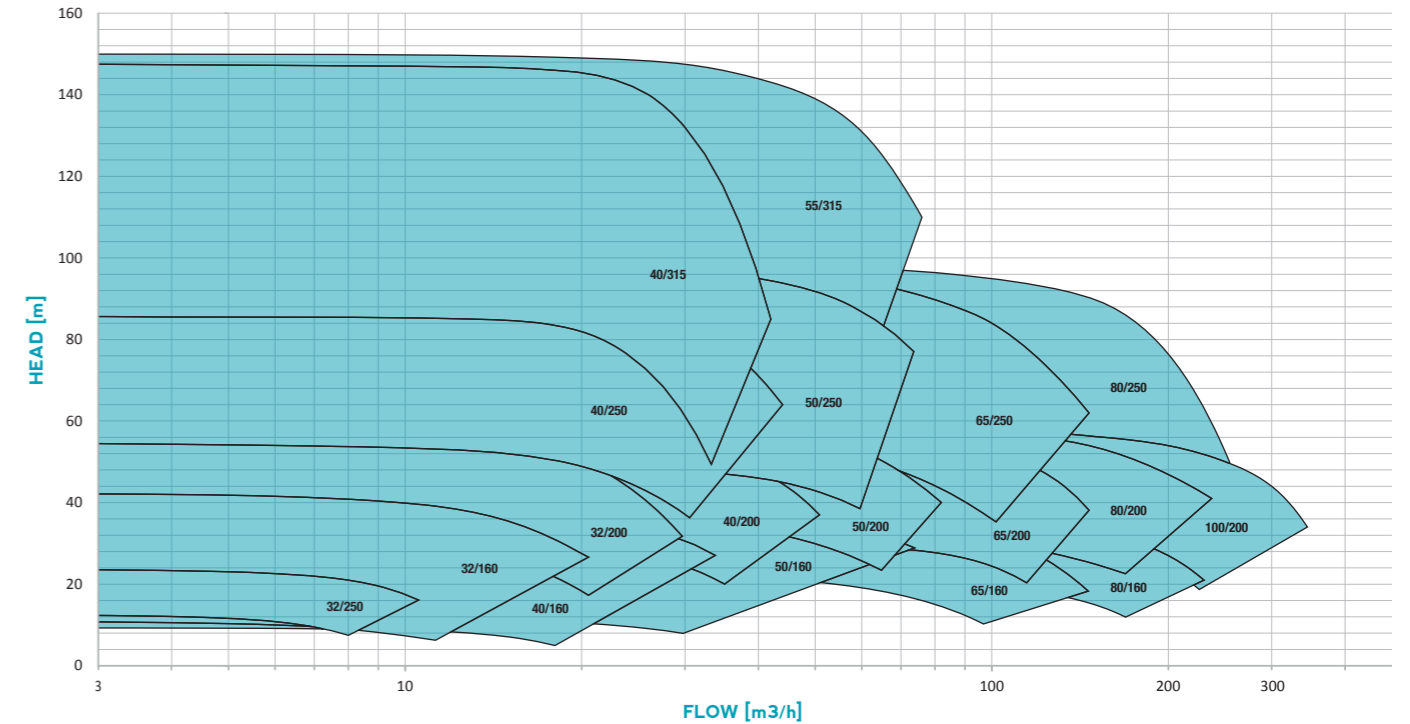

**CURVE RANGE 50HZ / 1450 RPM**

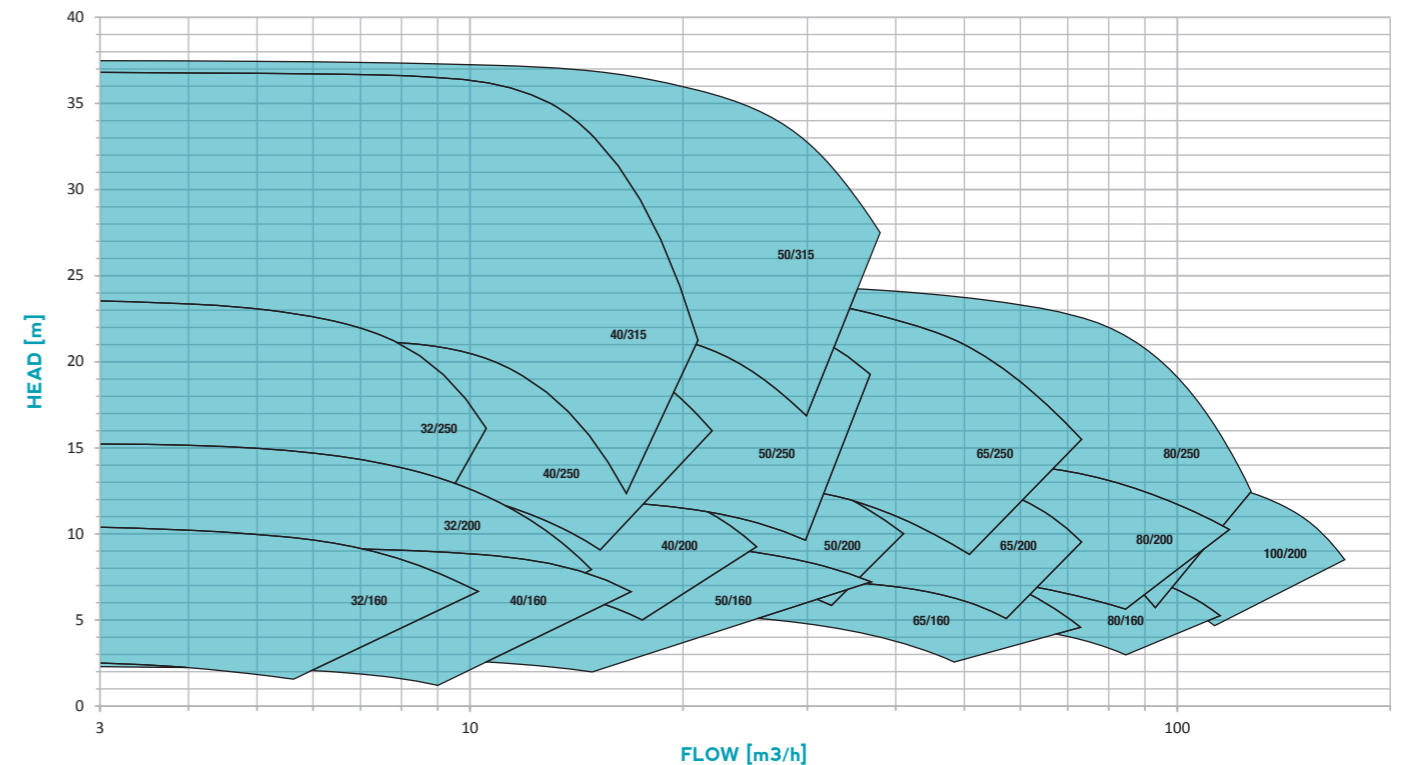

**+ SPECIFICATIONS OF DESIGN**

**STANDARD CONSTRUCTION**

- 1 Pump casing with flanges according to EN 1092-1, PN16 RF.
- 2 Magnetic coupling, driven part
- 3 Magnetic coupling, driving part
- 4 Shroud
- 5 Connection with standard electrical motor

**CONSTRUCTION OPTIONS**

- Welded drain with flange and valve
- Flanges according to ASME B16.5 #150 RF
- Inducer: for low NPSH application
- Levelling feet on the baseplate

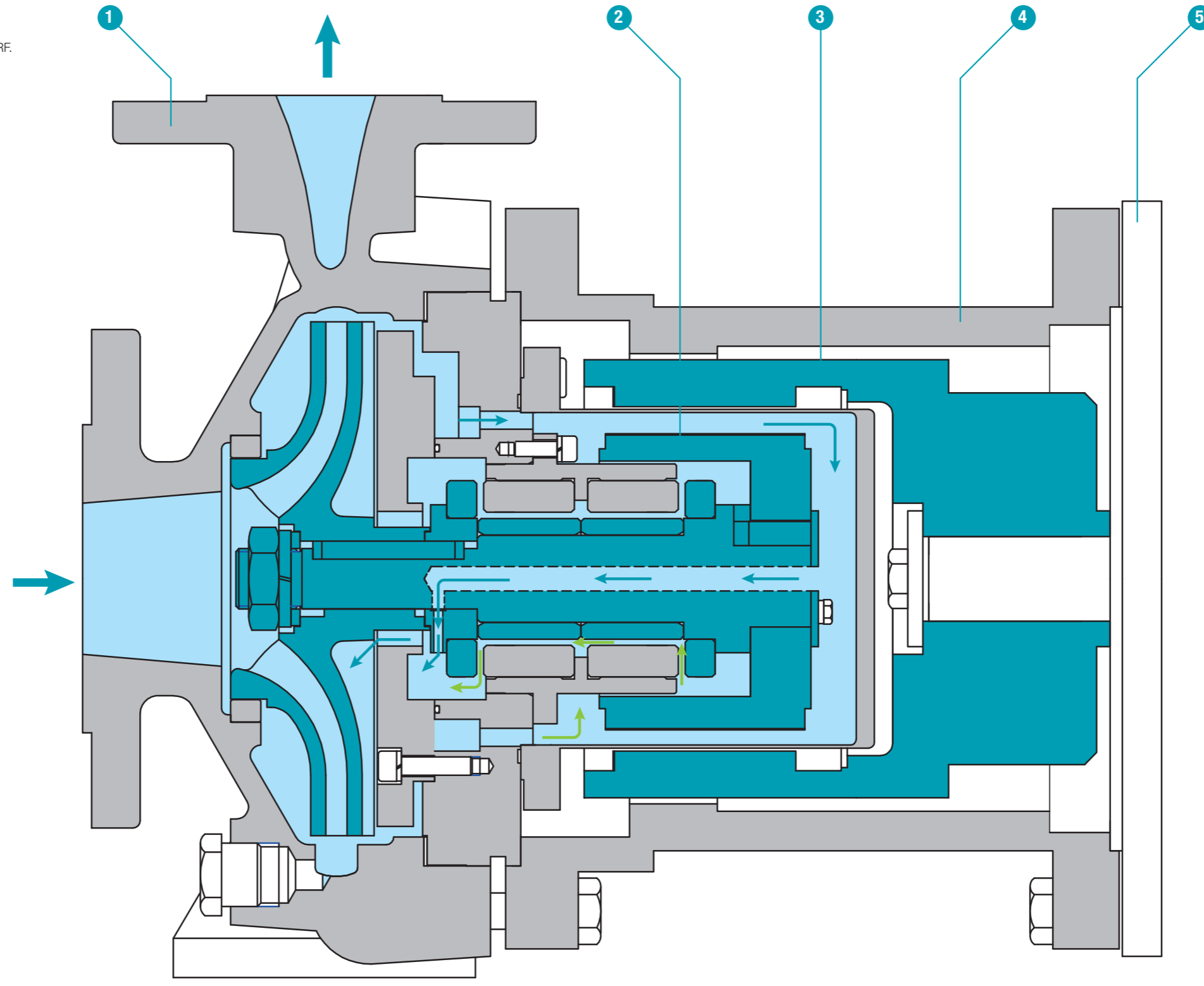

- ➔ Main circulation
- ➔ Bearing lubrication circulation
- Pumped liquid
- Rotating parts
- Hermetically sealed casing



**+ GENERAL ARRANGEMENT DRAWING  
FRAME CONSTRUCTION**

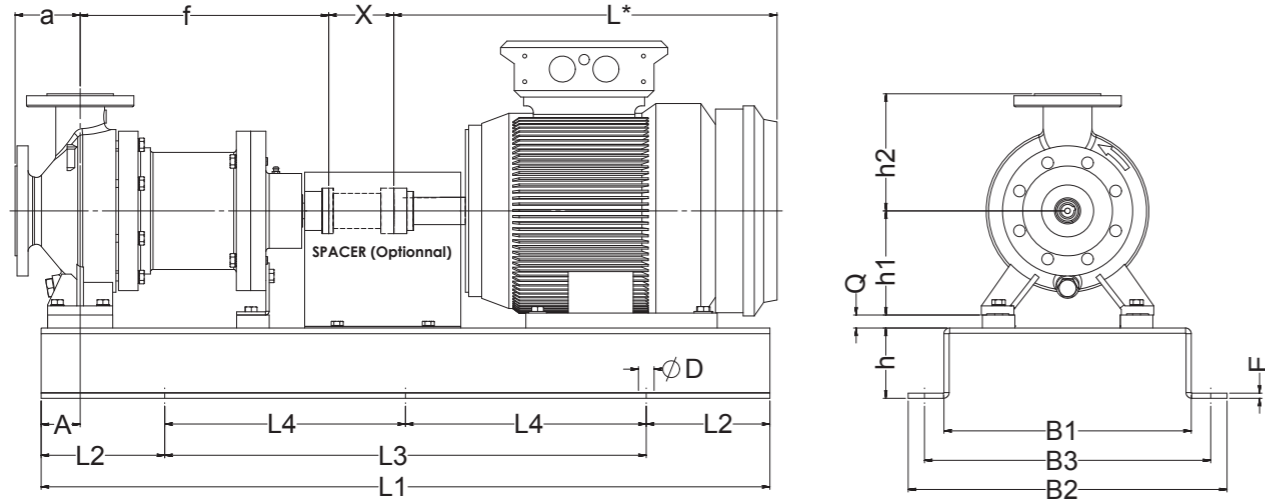

BASEPLATE Nbr	BASEPLATE DIMENSIONS (mm)									
	L1	L2	L3	L4	B1	B2	B3	h	ØD	E
2	800	130	540	-	270	360	320	80	4x20	8
3	900	150	600	-	300	390	350	80	4x20	8
4	1000	170	660	-	340	450	400	80	4x24	8
5	1120	190	-	370	380	490	440	100	6x24	8
6	1250	205	-	420	430	540	490	100	6x24	8
7	1400	230	-	470	480	610	550	100	6x28	10
8	1600	270	-	530	530	660	600	100	6x28	10
9	1800	300	-	600	600	730	670	100	6x28	12
10	2000	330	-	670	730	910	830	100	6x28	12

Hydraulic size	DN		PUMP DIMENSIONS (mm)				A	COUPLING		CHOICE OF BASEPLATE AND CASING WEDGE																					
	IN	OUT	a	f	h1	h2		X		BASEPLATE Nbr according to ISO 3661/Q (Wedge thickness in mm)																					
								WITH	WITHOUT	IEC	80L	90S	90L	100L	112M	132S	132M	160M	160L	180M	180L	200L	225S	225M	250M	280S	280M				
										P (kW)	2 poles	0,75/1,1	1,5	2,2	3	4	5,5/7,5	9	11/15	18,5	22	-	30/37	-	45	55	75	90			
											4 poles	0,75	1,1	1,5	2,2/3	4	5,5	7,5	9/11	15	18,5	22	30	37	45	55	75	90			
50-32-125	50	32	80	385	112	140	60	100	3			3/32	3/32	3/32	3/32	3/0	4/20	5/20	5/48	5/48	5/68	5/68									
50-32-160	50	32	80	385	132	160	60	100	3			2/52	2/42	2/42	3/32	3/20	4/0	4/0	5/28	5/28	6/48	6/48	6/68								
50-32-200	50	32	80	385	160	180	60	100	3						3/60	3/48	4/28	4/28	5/0	5/0	6/20	6/20	6/40	6/65							
50-32-250	50	32	100	500	180	225	75	100	3						4/80	4/68	5/48	5/48	6/20	6/20	6/0	6/0	7/20	7/45	7/45	8/70	8/100				
65-40-125	65	40	80	385	112	140	60	100	3			3/32	3/32	3/32	3/32	3/0	4/20	5/20	5/48	5/48	5/68	5/68									
65-40-160	65	40	80	385	132	160	60	100	3			2/52	2/42	2/42	3/32	3/20	4/0	4/0	5/28	5/28	6/48	6/48	6/68								
65-40-200	65	40	100	385	160	180	60	100	3						3/60	3/48	4/28	4/28	5/0	5/0	6/20	6/20	6/40	5/65	9/65						
65-40-250	65	40	100	500	180	225	75	100	3						4/80	4/68	5/48	5/48	6/20	6/20	6/0	6/0	7/20	7/45	7/45	8/70	8/100				
65-40-315	65	40	125	500	200	250	75	100	3			5/120	5/110	5/110	5/100	5/88	5/68	5/68	6/40	6/40	6/20	6/20	7/0	7/25	7/25	8/50	9/80				
80-50-125	80	50	100	385	132	160	75x	100	3			3/52	3/42	3/42	3/32	3/20	4/0	5/0	5/28	5/28	6/48	6/48	7/68								
80-50-160	80	50	100	385	160	180	60	100	3			2/80	2/70	2/70	3/60	3/48	4/28	4/28	5/0	5/0	6/20	6/20	6/40	5/65	6/65						
80-50-200	80	50	100	385	160	200	60	100	3						3/60	3/48	4/28	4/28	5/0	5/0	6/20	6/20	6/40	5/65	6/65	7/90					
80-50-250	80	50	125	500	180	200	75	100	3						4/80	4/68	5/48	5/48	6/20	6/20	6/0	6/0	7/20	7/45	7/45	8/70	9/100				
80-50-315	80	50	125	500	225	280	75	X(**)	3								5/93	5/93	6/65	6/65	6/45	6/45	7/25	7/0	7/0	8/25	9/55	10/90			
100-65-125	100	65	100	385	160	180	75	100	3			3/80	3/70	3/70	3/60	3/48	4/28	4/28	5/0	5/0	6/20	6/20	6/40	5/65	6/65						
100-65-160	100	65	100	500	160	200	75	100	3						3/60	3/48	4/28	4/28	5/0	5/0	6/20	6/20	6/40	7/65	7/65						
100-65-200	100	65	100	500	180	225	75	100	3						4/80	4/68	5/48	5/48	6/20	6/20	6/0	6/0	7/20	7/45	7/45	8/70	8/100				
100-65-250	100	65	125	500	200	250	75	100	3			5/0	5/0	5/0	5/0	5/0	5/0	5/0	6/0	6/0	7/0	7/0	7/0	7/25	7/25	8/50	9/80				
125-80-160	125	80	125	500	160	225	75	100	3			4/80	4/70	4/70	4/60	4/48	5/28	5/28	6/0	6/0		6/20	7/40	6/65	7/65	8/90					
125-80-200	125	80	125	500	180	250	75	100	3								5/48	5/48	6/20	6/20	6/0	6/0	7/20	7/45	7/45	8/70	9/100				
125-100-200	125	100	125	500	200	280	90	X(**)	3									5/68	5/68	6/40	6/40	6/20	6/20	7/0	7/25	7/25	8/50	9/80	10/115		
125-80-250	125	80	125	500	225	280	90	X(**)	3								6/93	6/93	6/65	6/65	6/45	6/45	7/25	7/0	7/0	8/25	9/55	10/90			

L(\*) depends on the motor manufacturer / X(\*\*) Motor IEC160-250 : X = 100 , Motor IEC280 X=140

**+ INSTRUMENTATIONS**

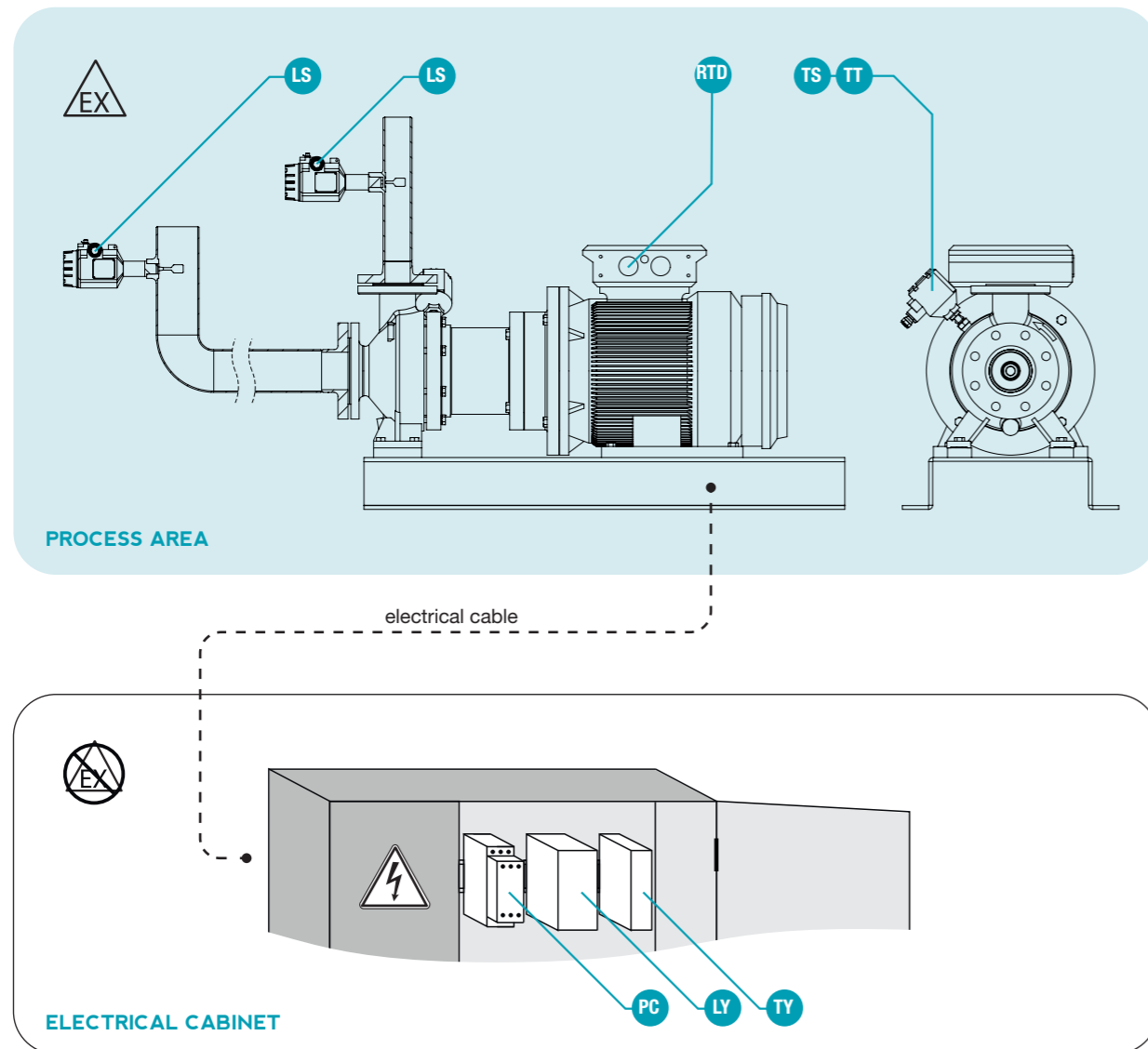

Rep	Type	Description	Use to	Location
TS TT	PT100	Liquid temp. element	Heating control of the liquid in the pump	Installed on the Lantern to measure the temperature on the shroud
RTD	PTC / PT100	Windings temp.	Motor heating control	Inside the motor
TY	-	Relay for PTC	-	Installed in the electrical cabinet
LS	Tuning fork	Liquid level sensor	Control liquid detection	Installed on the suction or the discharge piping
LY	-	Amplifier NAMUR for LS	-	Installed in the electrical cabinet
PC	Transducer	Power controller	Current consumption control	Installed in the electrical cabinet

**+ MAIN AND SPARE PARTS**

Mark	Qte	Designation	Materials	Recommended spare parts
102	1	Casing	stainless steel	
200	1	Shaft	stainless steel	•
230	1	Impeller	stainless steel	
231	1	Pressure impeller	stainless steel	
301	1	Bearing	SSIC	•
320	1	Shaft sleeve	SSIC	•
323	1	Bearing thrust	SSIC	•
440	1	Bearing support	Stainless steel	
450	1	Lantern	Cast iron	
600.01	1	Casing gasket	PTFE	•
600.02	1	Shroud gasket	PTFE	•
610.03	1	O-ring	NBR	•
800	1	Shroud	Hastelloy C4	•
810	1	Magnetic coupling, driving part	SmCo17	
820	1	Magnetic coupling, driven part	SmCo17	
830	1	Flywheel	Steel	

**LOCATION ON PUMP**

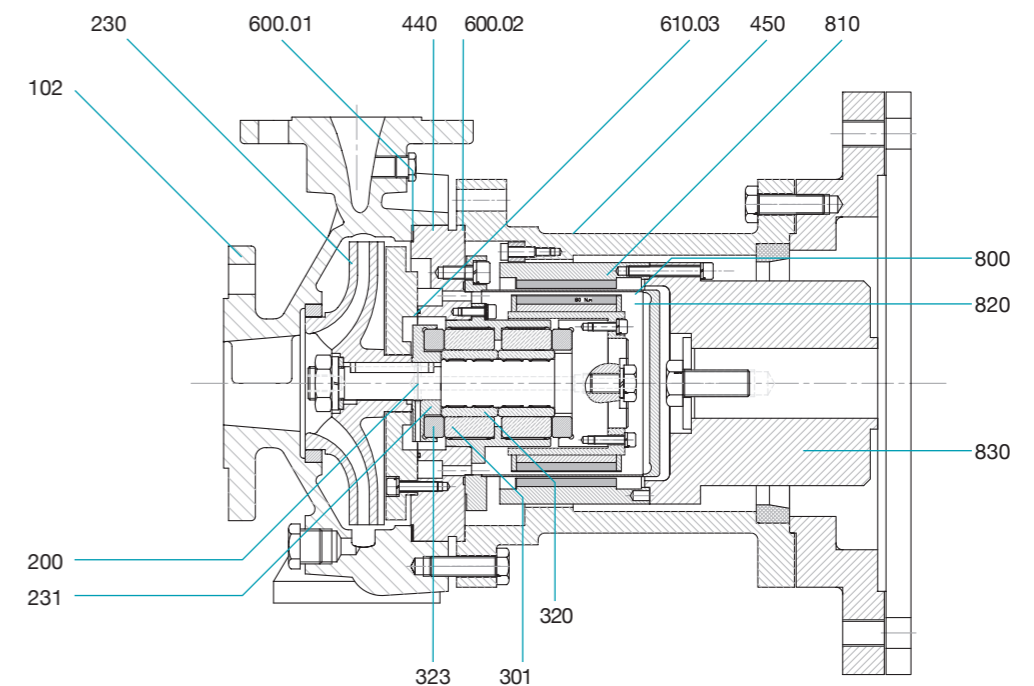



269, rue de Montepy  
69210 Fleurieux sur l'Arbresle  
France

Tél : +33 (0)4 72 52 95 74  
[contact@optimex-pumps.com](mailto:contact@optimex-pumps.com)

 **OPTIMEX**  
CANNED MOTOR PUMPS

[www.optimex-pumps.com](http://www.optimex-pumps.com)